

Carton contains:

- » 1 header and track assembly
- » 1 doorway end bracket
- » 1 pocket end bracket
- » 4 split studs
- » 2 floor plates
- » 1 bumper
- » 1 door hanging parts bag (2 hangers, 2 hanger plates, 2 door guides)

**NOTE: For bi-parting doors, use Hager Double Pocket Door Kit 9639 (sold separately).**



This kit joins two pocket door frames to make one large doorway. The rough opening width changes to four times one door width.

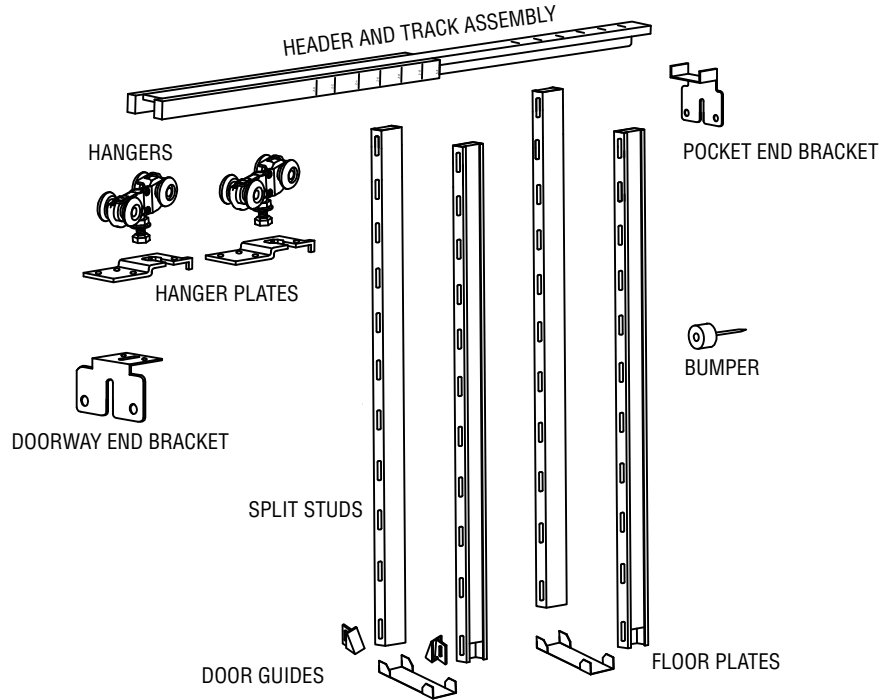

**STEP 1**

Construct the rough opening by following the guidelines below:

The minimum rough opening height from the finished floor to the header should be 84-1/2" (214.63 cm) for a 6'-8" (203.2 cm) door, 88-1/2" (224.79 cm) for a 7'-0" (213.36 cm) door, 100-1/2" (255.27 cm) for an 8'-0" (243.84 cm) door, or 112-1/2" (285.75 cm) for a 9'-0" (274.32 cm) door.

The rough opening width should equal two times the door width plus 1" (25.4 mm). For example, a 30" (76.2 cm) door multiplied by two equals 60" (152.4 cm) plus 1" (25.4 mm) equals a 61" (154.94 cm) rough opening width.

Next, plumb the rough studs and ensure that the floor is level.

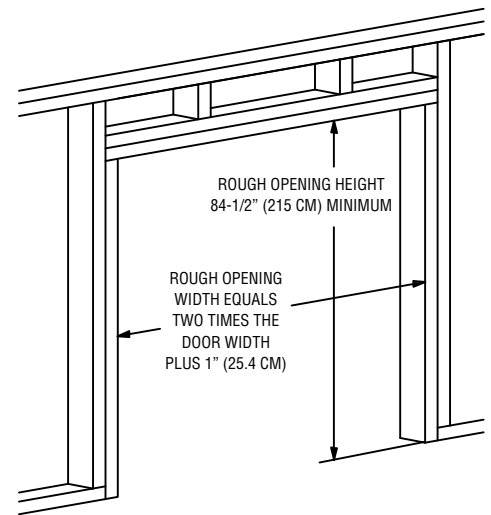

**STEP 2**

Prepare the header and track assembly. Note that the track in this kit will fit a 3'-0" (91.44 cm) door without modification, but it can easily be cut to accommodate any size door less than 3'-0" (91.44 cm), as shown below:

Cutting instructions for standard-width doors:

(A) Cut the wood header at the appropriate stamped size mark. Cut the header wood only.

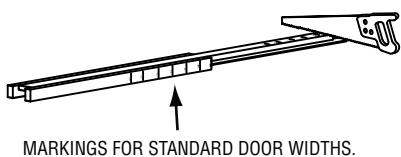

(B) Turn the header on its side to cut the nailing boards. Cut both nailing boards at the required marks--being careful not to cut the track.

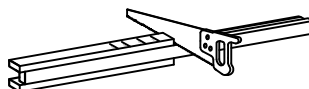

(C) Turn the track assembly back over and cut the track 1-1/2" (38.1 mm) back from the end of wood header.

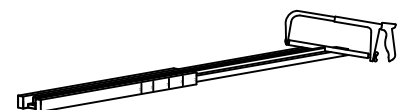

**STEP 3**

Determine the height of the finished floor. Then, mark each side of the rough opening above the finished floor at 80-3/4" (205.1 cm) for a 6'-8" (203.2 cm) door, 84-3/4" (215.26 cm) for a 7'-0" (213.36 cm) door, 96-3/4" (245.75 cm) for an 8'-0" (243.84 cm) door, or 108-3/4" (276.25 cm) for a 9'-0" (274.32 cm) door.

NOTE: If measuring from a rough sub-floor, be sure to add the estimated thickness of the finished floor material and/or carpeting.

Next, drive a flat-headed nail on the centerline of each framing stud at the mark, until only 1/8" (3.17 mm) of the nail is left protruding. The slot in the end brackets will slide over these nail heads.

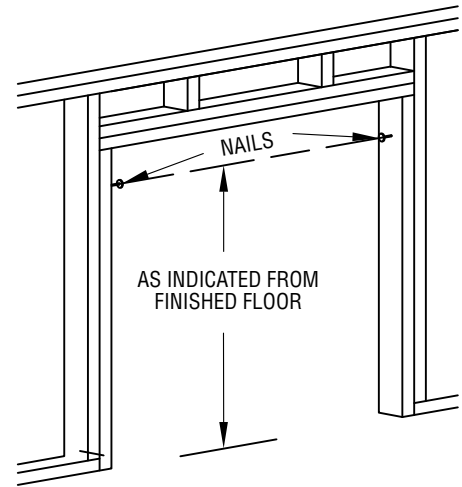

**STEP 4**

Slide the slot in the pocket end bracket over the nail head. Level it. Seat the nail. Double check, level, and drive additional nails. See Figure 1 to the right.

Next, mount the doorway end bracket to the jamb in the doorway. Level and secure it with additional nails. See Figure 2 to the right.

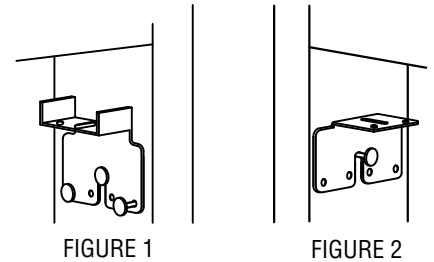

**STEP 5**

Snap two chalk lines on the floor, making sure they are even with the sides of the framing studs.

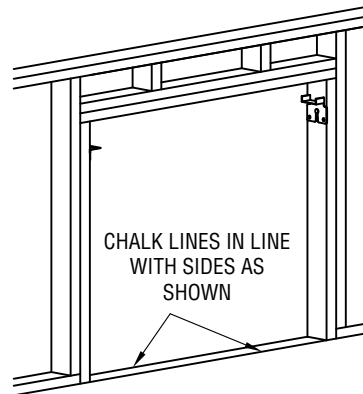

**STEP 6**

Attach the header and track.

NOTE: The header and track assembly should be installed with nailing boards over the doorway.

Set header and track assembly on the attached end brackets. Check to make sure that the nailing boards are over the doorway. With the screws provided, screw the end brackets to the header and track assembly in the pre-drilled holes in the header.

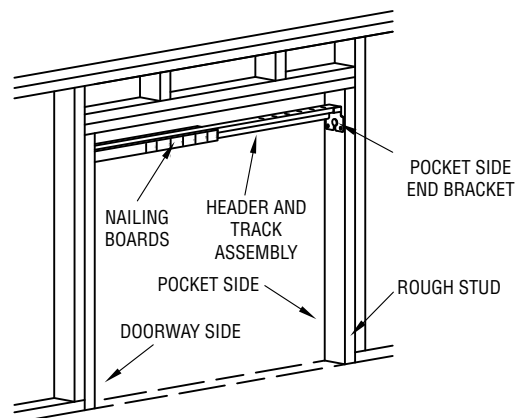

**STEP 7**

Lay down the floor plates between the chalk lines--one approximately in the center of the opening and the other approximately halfway between it and the rough stud of the pocket side.

---

**STEP 8**

Check the door thickness. When properly installed without modifications, this pocket door frame allows 2" (50.8 mm) of free space for the door between the split studs. A 1-3/8" (34.93 mm) door would leave 5/16" (7.94 mm) clearance on each side. A 1-3/4" (44.45 mm) door would leave 1/8" (3.18 mm) clearance on each side.

**NOTE: For additional clearance, floor plates may be cut and spread apart. Shims may also be inserted between header assembly and split studs. Or, you can use Hager's 9634 Door Adapter Kit (sold separately), which contains shims and wider floor plates for additional clearance with 1-3/4" (44.45 mm) thick doors.**

---

**STEP 9**

Engage ends of split studs onto floor plates so that the slots on the backside are against the header. If split studs must be shortened for shorter doors, determine which end of the stud has the slots close to the end and cut off the other end.

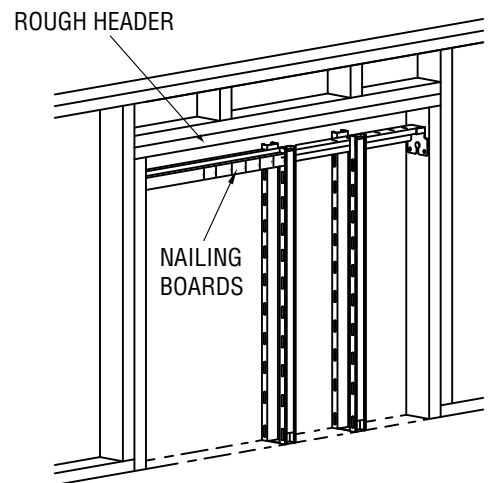
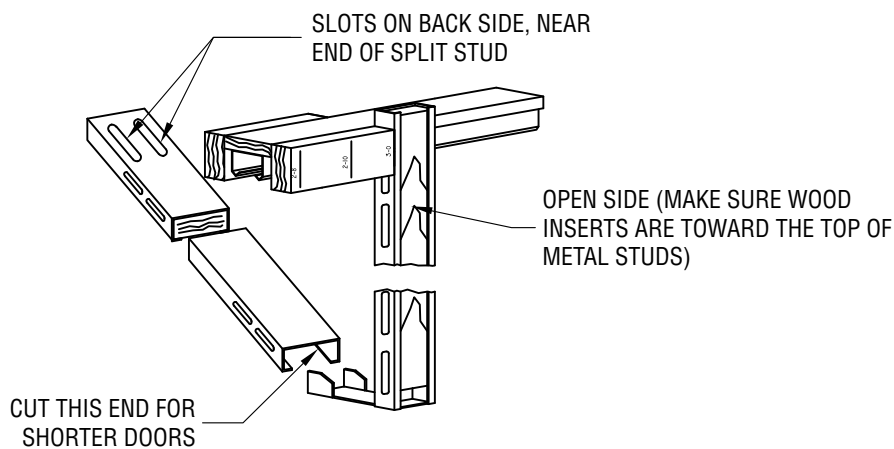

**NOTE:** For best results, pre-drill holes before screwing. Butt one pair of split studs against the header nailing boards and screw to header. Screw the other pair of split studs to the header midway between the first pair of split studs and the rough stud on the pocket side. Re-position the floor plates between the chalk lines. Plumb the split studs to make sure they are vertical and square. Screw floor plates to the floor.

For added security when using heavier doors, drill two 1/4" diameter holes, centered in the track, through the header--one in the approximate middle of the door opening and one in the middle of the pocket. Insert 3-1/2" long #6 or #8 pan head screws through holes and screw to rough header. Do not over-tighten to avoid bending track or header. Clean the inside of the track, removing drill shavings and saw dust.

**STEP 10**

To help prevent the door from becoming warped, guard against moisture absorption by sealing all edges of the door with paint or sealing stain.

**STEP 11**

Insert hangers into the track. Adjust the hanger bolt to the lowest position.

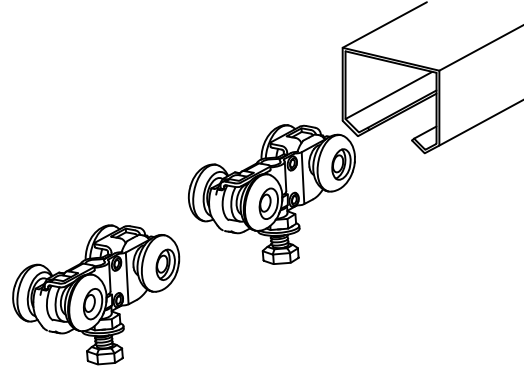

**STEP 12**

Install door hanger plates as shown below. Attach the bumper to the back edge of the door in its approximate center.

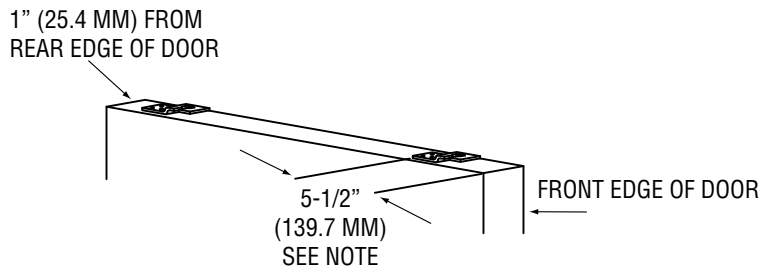

NOTE: When installing bi-parting pocket doors, change to 6-1/2" (165.1 mm) from the edge of the door.

**STEP 13**

Hang door, mounting rear edge first and the front edge second.

**STEP 14**

Install the vertical finish jambs, butting them all the way up against the exposed wood of the nailing boards and butting them to the header assembly, as shown below:

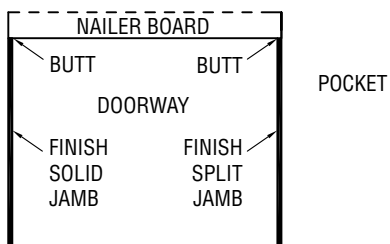

**STEP 15**

Adjust the door for height above the floor and for squareness to solid jamb by turning the adjusting bolt on each hanger with the wrench that was supplied. Finish by tightening the jam nuts to hold adjustment.

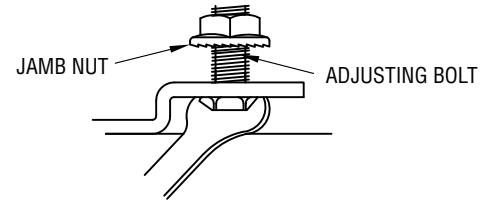

**STEP 16**

Install finish split header to the exposed wood on either side of the track. To allow for future door adjustment or removal, at least one finished split header should be attached with screws only; the one on your right-hand overhead as you face the door in the pocket.

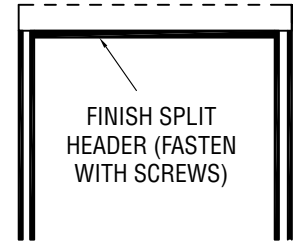

**STEP 17**

Install finish trim or casing. Fasten finish header trim to either header or wall, not both, so the header can be removed later without damage, if needed.

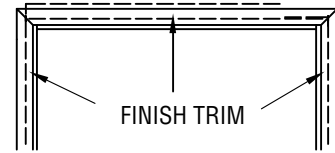

**STEP 18**

Install finish split jambs, leaving a 1/8" (3.18 mm) minimum clearance on both sides of doors.

Install door guides by attaching to split jambs at bottom of door.

